



STEELAB



SBA - Planter with Removable Growing Tray

Presentation

Assembled planter which external cladding receive one or more removable growing tray(s). The Steelab SBA range separates the "furniture" and "growing" functions of the planter to offer a host of functional possibilities. This makes it possible to limit the height of the soil and offer independent, manual handable elements without sacrificing the visible dimensions of the planter. Made in France to measure.

Description

The bottomless exterior cladding is made from thermo-lacquered panels, assembled without welding. The top edge is folded and counter-folded, with a horizontal return to support the growing trays. Vertical reinforcements take the load right down to the ground.

The growing area consists of one or more independent, removable plant trays in untreated galvanised steel. The height of the growing tray can be chosen independently of the height of the planter. It is made from panels that are assembled, glued and riveted together. The top edge is finished with a fold and a counter-fold. The cladding panels are assembled in mitre at the vertical edges or positioned at the most appropriate points depending on the layout (side walls, rear corners, etc.). All fixing and locking components are concealed once the planter is assembled.

Materials

Robust and economical, Z275 galvanised steel is an ideal solution for assembled planters, particularly when the powder-coated cladding is separate from the growing area. The SBA range uses it in thicknesses of 2 to 3mm, depending on the dimensions.

Variations can be offered in Magnelis®, Corten®, Stainless steel or aluminium where weight is an issue.

Finishes

The cladding panels are painted on the external faces and extended returns before assembly. Powder-coated : Pickling / Epoxy primer / Polyester finish.

Installation

The planters are delivered assembled and ready to install. However, if access is a problem, they can be supplied dismantled.

They are installed on adjustable feet. As an option, they can be supplied on castors, either visible or concealed. They can also be provided for sealing on ground.

The space available in the planter frees up a technical area that makes it easier to install watering, lighting and drainage systems. As an option, a cover can be substituted for a growing tray to make full use of this facility.

Water management

Assemblies are glued watertight. The planters are drained via a drain hole fitted with a drip guard at the bottom of each growing tray. The diameter can be adapted to suit the installation. As an option, a wall feed-through is available to catch dirty water flow, for example.

As an option, various horticultural systems are available offering good drainage and a water reserve.

The double walls naturally provide good thermal insulation for the growing area, limiting evaporation.

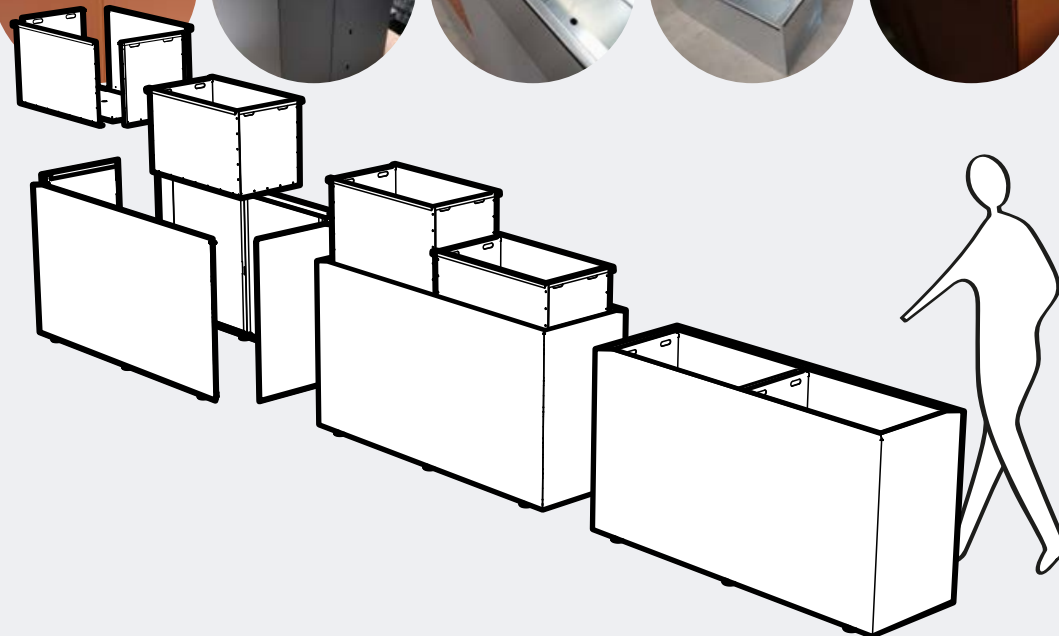
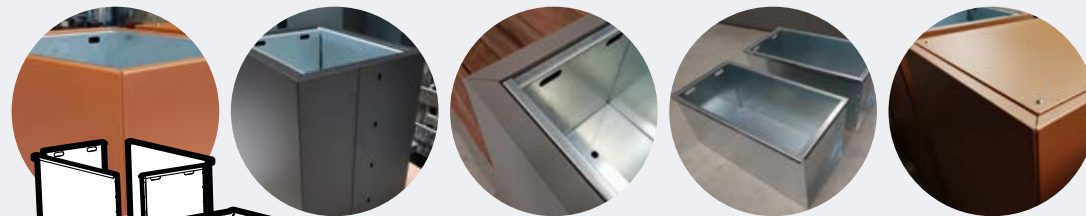

STEELAB
a brand
ATELIER SO GREEN

www.ateliersogreen.com

contact@ateliersogreen.com

T - 33 (0)2 47 65 13 62

Création Jean Claude Joly sarl
9, rue Allaire - ZA la Canterie
37800 Ste Maure de Touraine
FRANCE